

EN

OPERATING MANUAL
CLAMP METER



Table of contents

Notes regarding the operating manual..... 2

Safety 2

Information about the device..... 4

Transport and storage..... 6

Operation 7

Maintenance and repair 12

Errors and faults..... 12

Disposal 12

Notes regarding the operating manual

Symbols

 **Warning of electrical voltage**
This symbol indicates dangers to the life and health of persons due to electrical voltage.

 **Warning**
This signal word indicates a hazard with an average risk level which, if not avoided, can result in serious injury or death.

 **Caution**
This signal word indicates a hazard with a low risk level which, if not avoided, can result in minor or moderate injury.

Note
This signal word indicates important information (e.g. material damage), but does not indicate hazards.

 **Info**
Information marked with this symbol helps you to carry out your tasks quickly and safely.

 **Follow the manual**
Information marked with this symbol indicates that the operating manual must be observed.

You can download the current version of the operating manual and the EU declaration of conformity via the following link:



BE40



<https://hub.trotec.com/?id=43773>

Safety

Read this manual carefully before starting or using the device. Always store the manual in the immediate vicinity of the device or its site of use!

-  **Warning**
Read all safety warnings and all instructions. Failure to follow the warnings and instructions may result in electric shock, fire and / or serious injury.
Save all warnings and instructions for future reference.
- The device is supplied with a warning sign. Prior to initial start-up, make sure to paste the corresponding warning sign in your local language over the one present at the rear of the device as described in chapter Operation.



- Do not use the device in potentially explosive rooms.
- Do not use the device in aggressive atmosphere.
- Protect the device from permanent direct sunlight.
- Do not remove any safety signs, stickers or labels from the device. Keep all safety signs, stickers and labels in legible condition.
- Do not open the device.
- Observe the storage and operating conditions as given in the Technical data chapter.

Intended use

This device is intended for measurements in the measuring range and category (CAT III, 600 V) specified in the technical data.

To use the device for its intended use, only use accessories and spare parts which have been approved by Trotec.

Improper use

Do not use the device in potentially explosive atmospheres, when wet or very humid.

Unauthorized modifications of the device are forbidden.

Personnel qualifications

People who use this device must:

- master the 5 safety rules (1 De-energise, 2 Secure against restart, 3 Verify de-energised state (bipolar), 4 Earth and short-circuit, 5 Cover neighbouring live parts).
- use the voltage detector following safe working procedures.
- be aware of the dangers that occur when working with electric devices in damp areas.
- take measures to protect themselves from direct contact with live parts.
- have read and understood the operating manual, especially the Safety chapter.

Residual risks



Warning of electrical voltage

Electric shock due to insufficient insulation! Check the device for damages and proper functioning before each use.

If you detect damages, do not use the device any longer.

Do not use the device when wither the device or your hands are damp or wet!

Do not use the device when the battery compartment or the housing is open.



Warning of electrical voltage

Electric shock due to contact with live parts! Do not touch any live parts. Secure neighbouring live parts by covering them or by switching them off.



Warning of electrical voltage

When performing non-contact measurements of the current, disconnect the measuring cables from the device beforehand.



Warning of electrical voltage

Work on the electrical components must only be carried out by an authorised specialist company!



Warning

Risk of suffocation!

Do not leave the packaging lying around. Children may use it as a dangerous toy.



Warning

The device is not a toy and does not belong in the hands of children.



Warning

Dangers can occur at the device when it is used by untrained people in an unprofessional or improper way! Observe the personnel qualifications!



Caution

Keep a sufficient distance from heat sources.

Note

To avoid damages to the device, make sure that the correct measuring range is selected before carrying out a measurement.

If you are unsure, select the largest measuring range. Unplug the measuring cable before changing the measuring range.

Note

Test the device for proper functioning at a known voltage source before each measurement.

Note

To prevent damages to the device, do not expose it to extreme temperatures, extreme humidity or moisture.

Note

Do not use abrasive cleaners or solvents to clean the device.

Information about the device

Device description

Using the clamp meter BE40 you can easily measure the amperage of alternating currents, AC and DC voltages as well as resistances.

Furthermore, you can check the continuity of circuits, fuses and contacts and test the forward voltage of diodes without the need for contact.

The current measurement is effected without contact via the electromagnetic field, which is why the electric circuit doesn't have to be interrupted for this method. Therefore, running systems, which cannot be switched off separately, can also be checked.

Owing to the galvanic isolation, the measuring signal is also potential-free towards the variable to be measured.

Device depiction

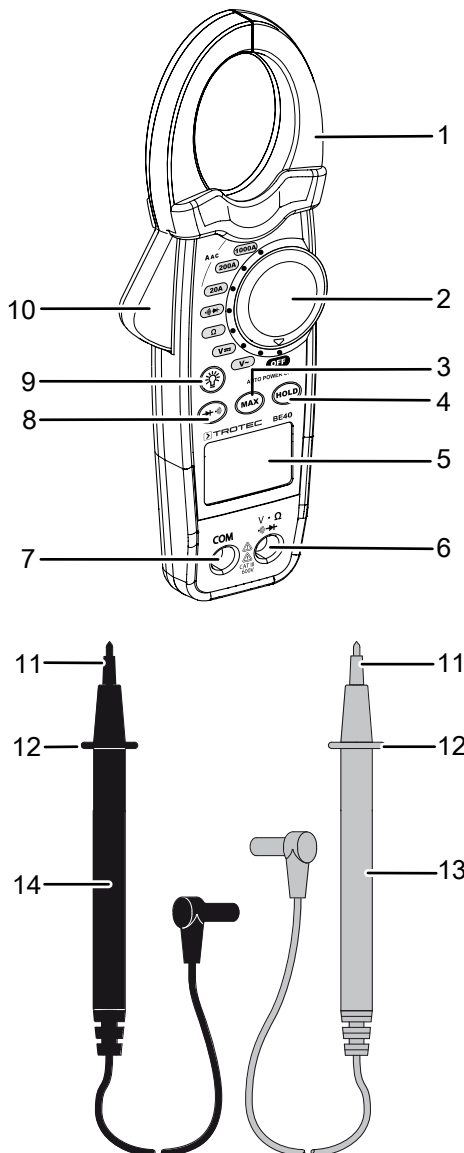

No.	Designation
1	Clamp
2	Rotary switch
3	MAX button (maximum value display)
4	HOLD button (freezing the display)
5	Display
6	Input connection for measuring cable (red)
7	COM connection for measuring cable (black)
8	Diode test / continuity test button
9	Display illumination on/off button (hold for 3 s)
10	Lever for opening the clamp
11	Test probes
12	Protection against contact
13	Red measuring cable
14	Black measuring cable

Rotary switch

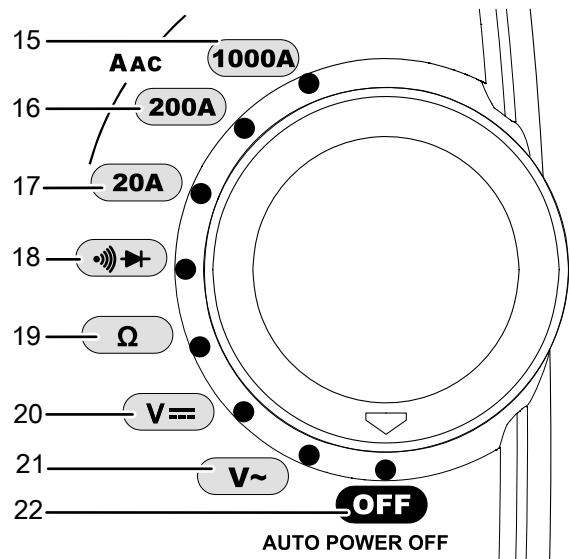

No.	Designation
15	Measuring alternating current of up to 1000 A
16	Measuring alternating current of up to 200 A
17	Measuring alternating current of up to 20 A
18	Diode test / continuity test
19	Measuring resistance
20	Measuring DC voltage
21	Measuring AC voltage
22	OFF (for switching the device off)

Display

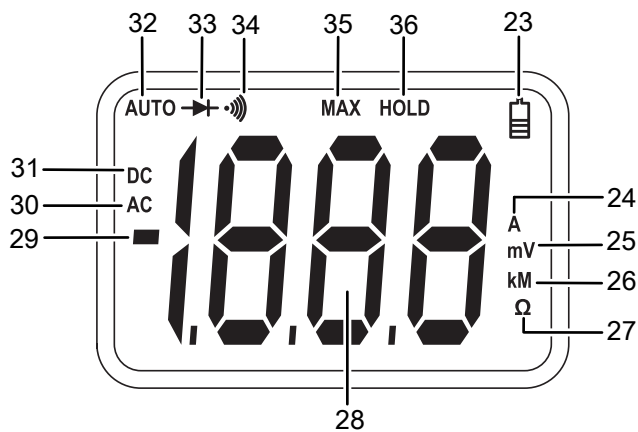

No.	Purpose of the indication
23	Battery loading status
24	Unit for amperage (A)
25	Unit for voltage (mV / V)
26	Unit for resistance (kΩ / MΩ)
27	Resistance measurement
28	Measurement value display
29	Minus sign (positive and negative poles confused)
30	AC measurement
31	DC measurement
32	Automatic measuring range selection
33	Diode test
34	Continuity test
35	<i>MAX</i> indication (indication of the maximum value)
36	<i>HOLD</i> indication (display of the measured value is frozen)

Technical data

Parameter	Value
Model	BE40
Size of the clamp opening	approx. 30 mm
Diode test	test current of 0.3 mA open-circuit voltage: 1.5 V DC
Continuity test	threshold < 120 Ω; test current < 1 mA
Measuring range exceeded	<i>OL</i> is displayed
Measuring rate	2 per second
Input impedance	7.8 MΩ (V DC and V AC)
Frequency range alternating current	50/60 Hz (A AC)
Frequency range AC voltage	50/60 Hz (V AC)
Operating temperature	-10 °C to 50 °C (-14 °F to 122 °F)
Storage temperature	-30 °C to 60 °C (-22 °F to 140 °F)
Relative humidity	up to 85 %
Overvoltage protection	category III, 600 V
Battery	2 x 1.5 V batteries of type AAA
Automatic switch-off	after approx. 15 minutes
Dimensions (length x width x height)	229 x 48 x 80 mm
Weight	approx. 303 g

Measuring ranges

Measuring level	Measuring range	Resolution	Accuracy (% of the reading)
Alternating current			
20 A	0 A to 20.00 A	0.01 A	± (2.5 % + 10 digits)
200 A	0 A to 200.0 A	0.1 A	± (2.5 % + 10 digits)
1000 A	0 A to 1000 A	1 A	± (3.0 % + 8 digits)
DC voltage			
200 mV	0 mV to 200.0 mV	0.1 mV	± (0.8 % + 5 digits)
2 V	0 mV to 2000 mV	0.001 V	± (1.2 % + 3 digits)
20 V	0 V to 20.00 V	0.01 V	± (1.2 % + 3 digits)
200 V	0 V to 200.0 V	0.1 V	± (1.2 % + 3 digits)
600 V	0 V to 600.0 V	1 V	± (1.5 % + 3 digits)
AC voltage			
200 mV	0 mV to 200.0 mV	0.1 mV	± (1.5 % + 30 digits)
2 V	0 mV to 2000 mV	0.001 V	± (1.5 % + 3 digits)
20 V	0 V to 20.00 V	0.01 V	± (1.5 % + 3 digits)
200 V	0 V to 200.0 V	0.1 V	± (1.5 % + 3 digits)
600 V	0 V to 600.0 V	1 V	± (2.0 % + 4 digits)
Resistance			
200 Ω	0 Ω to 200.0 Ω	0.1 Ω	± (1.0 % + 4 digits)
2 kΩ	0 Ω to 2000 Ω	1 Ω	± (1.5 % + 2 digits)
20 kΩ	0 kΩ to 20.00 kΩ	10 Ω	± (1.5 % + 2 digits)
200 kΩ	0 kΩ to 200.0 kΩ	100 Ω	± (1.5 % + 2 digits)
2 MΩ	0 MΩ to 2.000 MΩ	1 kΩ	± (2.0 % + 3 digits)
20 MΩ	0 MΩ to 20.00 MΩ	10 kΩ	± (3.0 % + 5 digits)

Scope of delivery

- 1 x Device
- 1 x Red measuring cable
- 1 x Black measuring cable
- 2 x 1.5 V battery AAA
- 1 x Bag / holster
- 1 x Manual

Transport and storage

Note

If you store or transport the device improperly, the device may be damaged.

Note the information regarding transport and storage of the device.

Transport

For transporting the device, use the bag included in the scope of delivery in order to protect the device from external influences.

Storage

When the device is not being used, observe the following storage conditions:

- dry and protected from frost and heat
- protected from dust and direct sunlight
- with a cover to protect it from invasive dust if necessary
- The storage temperature is the same as the range given in the Technical data chapter.
- Remove the batteries from the device.

Operation

Inserting the batteries

Insert the batteries contained in the scope of delivery (2 x 1.5 V AAA) before first use.

Note

Make sure that the surface of the device is dry and the device is switched off.

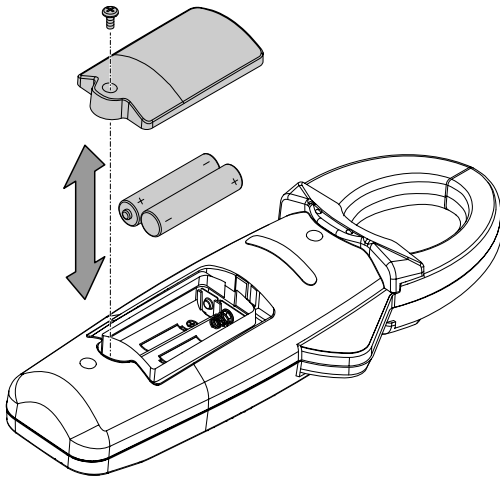

Please proceed as follows to insert the batteries into the device:

1. Loosen the screw at the rear of the device and open the cover of the battery compartment.
2. Insert the batteries into the battery compartment with correct polarity.
3. Close the battery compartment and fasten the cover in place.



Info

Please note that moving from a cold area to a warm area can lead to condensation forming on the device's circuit board. This physical and unavoidable effect can falsify the measurement. In this case, the display shows either no measured values or they are incorrect. Wait a few minutes until the device has become adjusted to the changed conditions before carrying out a measurement.

Attaching the warning sign

Prior to initial start-up, check whether the warning sign at the rear of the device is in your local language, if not, paste the proper one over it. A warning sign in your native language is supplied along with the device. Please proceed as follows to attach the warning sign to the rear of the device:

1. Remove the label in your local language from the supplied film.
2. Affix the label in the intended position at the rear of the device.

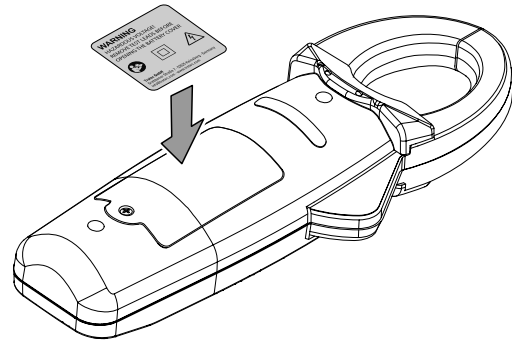

Performing a voltage measurement



Warning of electrical voltage

Risk of electric shock and risk of injury!

- Make sure to observe the device's nominal voltage specified in the technical data during the measurement.
- Check the measuring lines for damaged insulation before each measurement.
- Test the device for proper functioning at a known voltage source before each measurement.
- When holding onto the measuring cables, make sure not to reach behind the protection against contact (12):

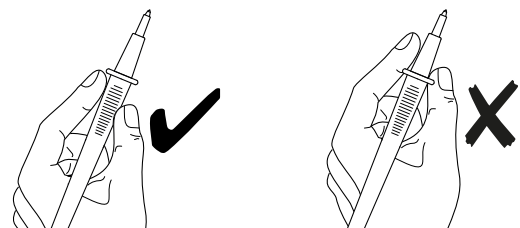

Measuring DC voltage

1. Connect the black measuring cable (14) to the COM connection (7) and the red measuring cable (13) to the Input connection (6).
2. Turn the rotary switch (2) to the measuring DC voltage position (20).
 - ⇒ The DC measurement indication (31) appears on the display.
3. Tap the desired measuring points of the electric circuit with the test probes (11) at the measuring cables with correct polarity.
 - ⇒ The measured value will be displayed in the measurement value display (28).
 - ⇒ The voltage unit (25) is displayed.



Info

If the minus sign (29) appears in front of the measured value, you have confused the measuring object's plus pole with the minus pole. Check the connection and connect the measuring cables with correct polarity.

Example:

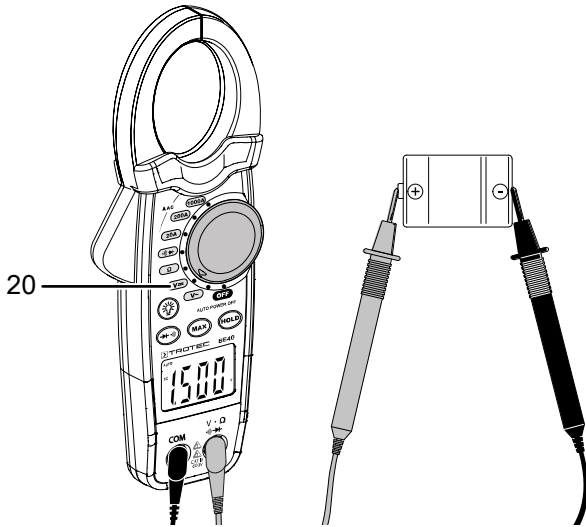

Measuring AC voltage

1. Connect the black measuring cable (14) to the COM connection (7) and the red measuring cable (13) to the Input connection (6).
2. Turn the rotary switch (2) to the measuring AC voltage position (21).
 - ⇒ The AC measurement indication (30) appears on the display.
3. Tap the desired measuring points of the electric circuit with the test probes (11) at the measuring cables.
 - ⇒ The measured value will be displayed in the measurement value display (28).
 - ⇒ The voltage unit (25) is displayed.

Example:

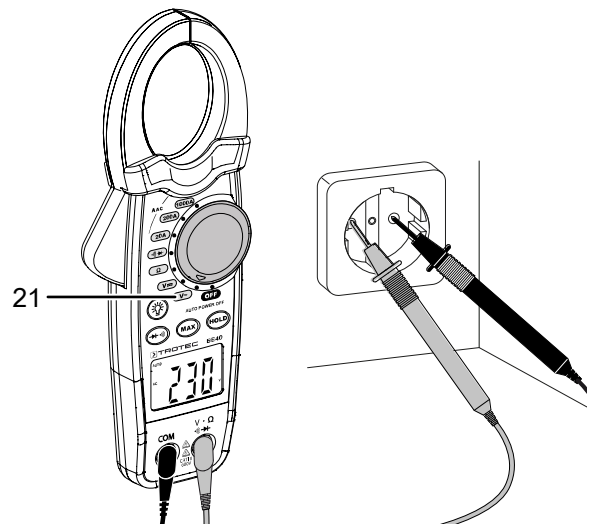

Measuring resistance



Warning of electrical voltage

Risk of electric shock and risk of injury when measuring the resistance!

Make sure that the power of the electric circuit is switched off and all capacitors are completely discharged.

- When holding onto the measuring cables, make sure not to reach behind the protection against contact (12).

Please proceed as follows to measure the resistance:

1. Connect the black measuring cable (14) to the COM connection (7) and the red measuring cable (13) to the Input connection (6).
2. Turn the rotary switch (2) to the measuring resistance position (19).
 - ⇒ The resistance measurement indication (27) appears on the display.
3. Tap the desired measuring points of the electric circuit with the test probes (11) at the measuring cables.
 - ⇒ The measured value will be displayed in the measurement value display (28).
 - ⇒ The resistance unit (26) is displayed (k = kilo = 1000 ohms, M = mega = 1 million ohms).

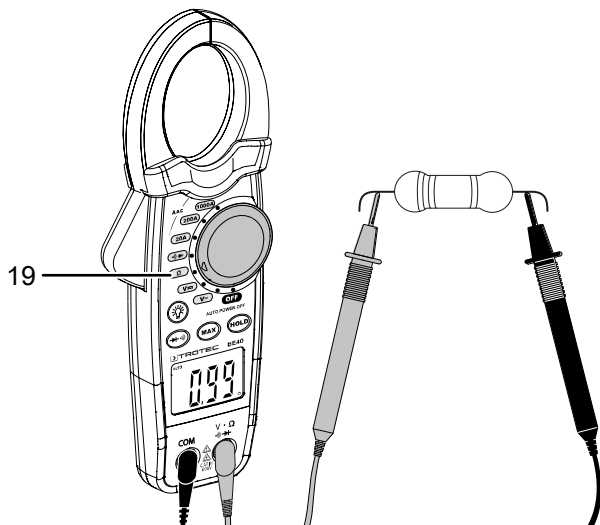

Please proceed as follows to check the continuity of the circuit to be tested:

1. Connect the black measuring cable (14) to the COM connection (7) and the red measuring cable (13) to the Input connection (6).
2. Turn the rotary switch (2) to the diode test / continuity test position (18).
3. Press the diode test / continuity test button (8) until the continuity test indication (34) appears on the display.
 - ⇒ The resistance measurement indication (27) appears on the display.
 - ⇒ *OL* is indicated on the measurement value display (28).
4. Tap the desired measuring points of the electric circuit with the measuring cables' test probes (11).
 - ⇒ If the measured resistance value amounts to less than 120 Ω , the device will emit an acoustic signal and the measurement value display (28) will indicate the resistance of the electric circuit.
 - ⇒ If the measured resistance value amounts to more than 120 Ω , the device will **not** emit an acoustic signal and the measurement value display (28) will continue to indicate *OL*.

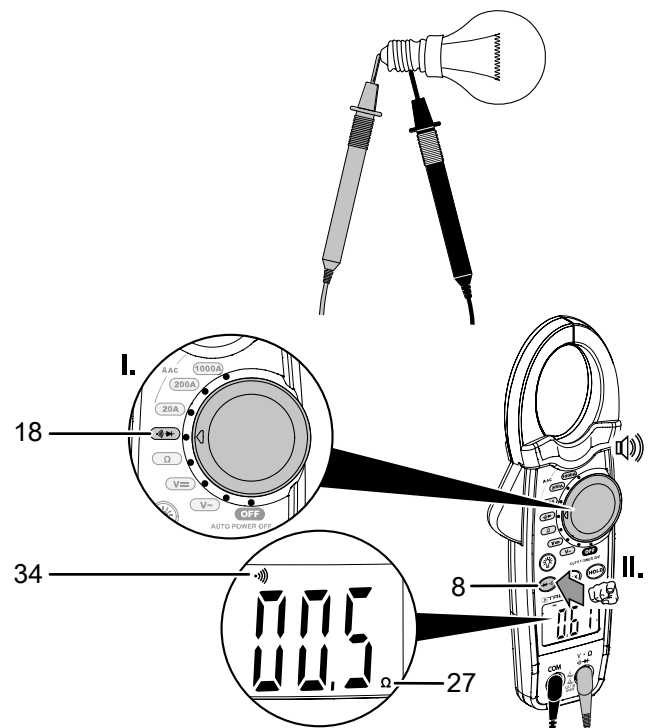

Continuity testing



Warning of electrical voltage

Risk of electric shock and risk of injury when checking the continuity!

Make sure that the power of the electric circuit is switched off and all capacitors are completely discharged.

- When holding onto the measuring cables, make sure not to reach behind the protection against contact (12).

Diode testing



Warning of electrical voltage

Risk of electric shock and risk of injury when testing diodes!

Make sure that the electric circuit to be tested is switched off and de-energized.

- When holding onto the measuring cables, make sure not to reach behind the protection against contact (12).

Please proceed as follows to test the forward voltage of a diode:

- ✓ The electrical circuit is deactivated.
 - ✓ All capacitors are completely discharged.
1. Connect the black measuring cable (14) to the COM connection (7) and the red measuring cable (13) to the Input connection (6).
 2. Turn the rotary switch (2) to the diode test / continuity test position (18).
 3. Press the diode test / continuity test button (8) until the diode test indication (33) appears on the display.
 4. Connect the test probe (11) of the red measuring cable (13) to the diode's anode (+).
 5. Connect the test probe (11) of the black measuring cable (14) to the diode's cathode (-).
 - ⇒ The diode's approximate forward voltage will be displayed in the measurement value display (27).
 - ⇒ The voltage unit (25) is displayed.
 - ⇒ If *OL* is indicated on the display, the test probes are not positioned correctly.

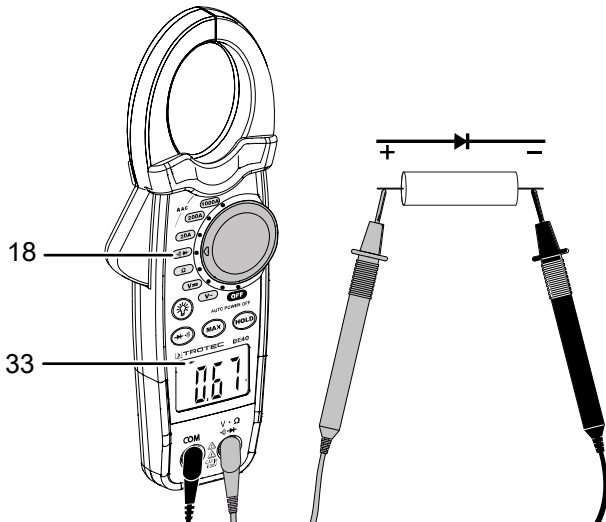

Measuring alternating current (AC)



Warning of electrical voltage

Risk of electric shock and risk of injury!

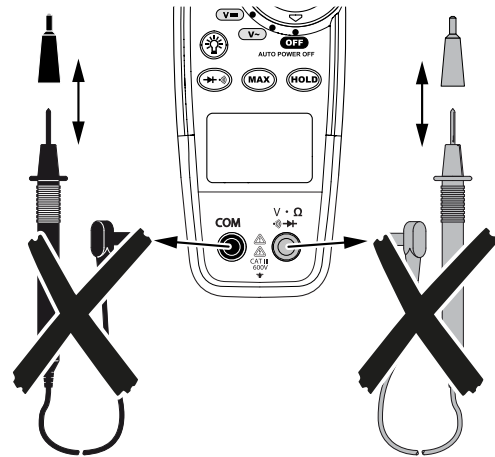

- When performing non-contact measurements, disconnect the measuring cables (13, 14) from the device.
- For current measurements align the conductor to be tested in the centre of the clamp.
- When holding onto the clamp meter, make sure not to touch the clamp (1).

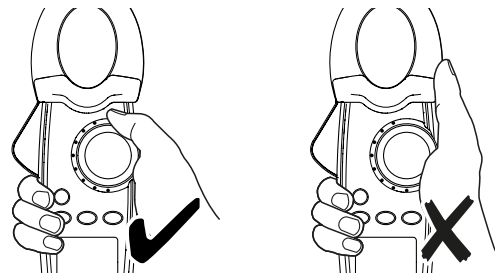

Info

Only measure one conductor at a time to ensure an unambiguous measurement result.

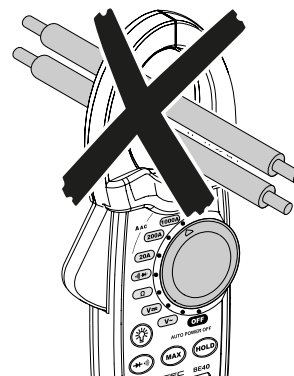

Please proceed as follows to measure the alternating current (AC):

1. Depending on the desired measuring range turn the rotary switch (2) to position (15) for a current of up to 1000 A, to position (16) for a current of up to 200 A or to position (17) for a current of up to 20 A.
 - ⇒ The AC measurement indication (30) lights up on the display.
2. Squeeze the lever (10) to open the clamp and insert the conductor to be measured centrally in the clamp.
3. Release the lever again to close the clamp of the clamp meter.
 - ⇒ The measured value will be displayed in the measurement value display (28).
 - ⇒ The unit for amperage (24) is displayed.

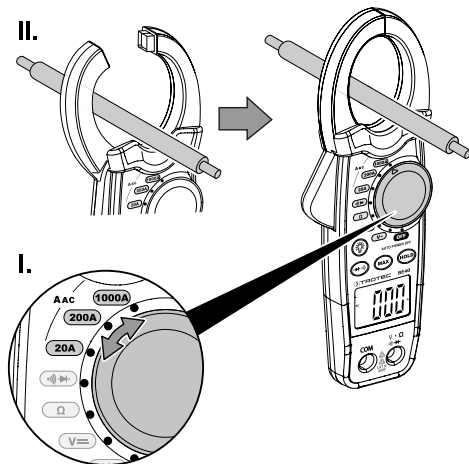

Freezing the displayed measured value

The hold function allows you to freeze the currently measured result in the measurement value display (28). To do so, please proceed as follows:

1. Carry out a measurement.
2. Press the *HOLD* button (4).
 - ⇒ An acoustic signal is emitted.
 - ⇒ The current measured value is frozen in the measurement value display (28).
 - ⇒ The *HOLD* indication (36) appears on the display.
3. Press the *HOLD* button (4) again to deactivate the HOLD function.

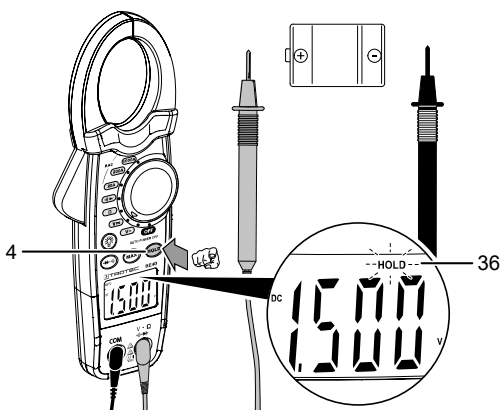

Displaying the maximum value

✓ You have carried out several measurements.

1. Press the *MAX* button (3).
 - ⇒ The *MAX* indication (35) appears on the display.
 - ⇒ The highest of the measured values is displayed in the measurement value display (28).
2. Press the *MAX* button (3) again to deactivate the maximum value display function.

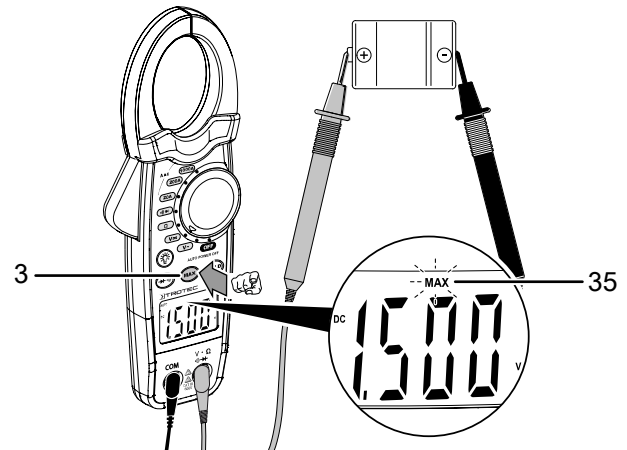

Switching the display illumination on/off

1. Press and hold the display illumination on/off button (9) for 3 seconds to switch on the display illumination.
2. With activated display illumination, press and hold the display illumination on/off button (9) for 3 seconds to switch the display illumination back off.

Switch-off

The device switches off automatically after 15 minutes of non-use.

1. Turn the rotary switch (2) to the switch position *OFF* (22).
 - ⇒ The device switches off.

Maintenance and repair

Cleaning

Clean the device with a soft, damp and lint-free cloth. Make sure that no moisture enters the housing. Do not use any sprays, solvents, alcohol-based cleaning agents or abrasive cleaners, but only clean water to moisten the cloth.

Repair

Do not modify the device or install any spare parts. For repairs or device testing, contact the manufacturer.

Errors and faults

The device has been checked for proper functioning several times during production. If malfunctions occur nonetheless, check the device according to the following list.

Display segments are only faintly visible or flicker:

- The battery voltage is too low. Exchange the batteries immediately.

The device displays implausible measured values:

- The battery voltage is too low. Exchange the batteries immediately.
- The opening of the current clamp is dirty. Clean the device as described in the Cleaning chapter.

Disposal



The icon with the crossed-out waste bin on waste electrical or electronic equipment stipulates that this equipment must not be disposed of with the household waste at the end of its life. You will find collection points for free return of waste electrical and electronic equipment in your vicinity. The addresses can be obtained from your municipality or local administration. For further return options provided by us please refer to our website www.trotec24.com.

The separate collection of waste electrical and electronic equipment aims to enable the re-use, recycling and other forms of recovery of waste equipment as well as to prevent negative effects for the environment and human health caused by the disposal of hazardous substances potentially contained in the equipment.



In the European Union, batteries and accumulators must not be treated as domestic waste, but must be disposed of professionally in accordance with Directive 2006/66/EC of the European Parliament and of the Council of 6 September 2006 on batteries and accumulators. Please dispose of batteries and accumulators according to the relevant legal requirements.

Trotec GmbH

Grebener Str. 7
D-52525 Heinsberg

☎ +49 2452 962-400

☎ +49 2452 962-200

✉ info@trotec.com

www.trotec.com